

# exact

## PipeCut 170/170E System

**EN** Users Manual

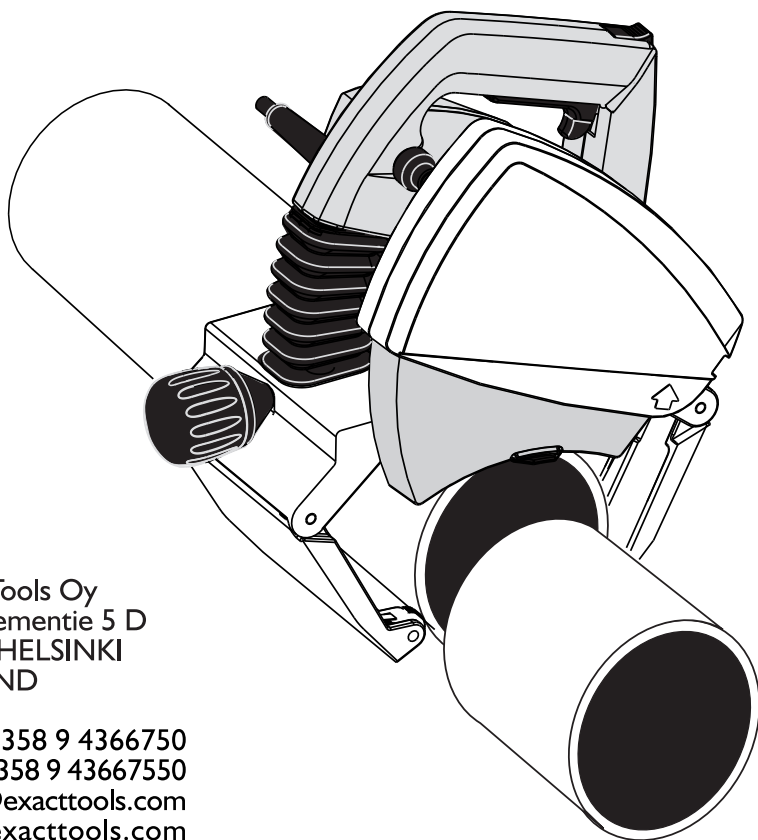

Exact Tools Oy  
Särkiniementie 5 D  
00210 HELSINKI  
FINLAND

Tel +358 9 4366750  
Fax +358 9 43667550  
[exact@exacttools.com](mailto:exact@exacttools.com)  
[www.exacttools.com](http://www.exacttools.com)

**Patent No. 1301311 EP, 108927 FI    Made in EU**

# Exact PipeCut 170/170E System Users manual

## Guarantee of conformity with EU requirements



We Exact Tools Oy, Särkiniementie 5 D 00210 Helsinki, Finland, guarantee that the Exact PipeCut 170/170E to which this statement refers fulfills the basic health and safety requirements mentioned in the (machine directive) EU directive 98/37/EY. Also the Exact PipeCut 170/170E fulfills the requirements of standard EN 60745-1:2003 + A1:2003 safety of hand-held electric motor operated tools and the applicable parts of standard EN 60745-2-5 particular requirements for circular saws and circular knives.

Also the Exact PipeCut 170/170E complies with the essential protection requirements of the Council Directive 89/336/EEC as stated in the Article 4 and the tested product is in compliance with the following Product Family standards:2006/95/EC, 98/37/EC, 2004/108/EC, EN 60745-1:2006, EN 60745-2-5:2007, EN 55014-1: 2006, EN 55014-2:1997 + A1:2001, EN 61000-3-2: 2006, EN 61000-3-3: 1995 + A1: 2001.

Helsinki 30.06.2008

A handwritten signature in black ink, appearing to read 'Seppo Makkonen', is written over a light grey circular stamp.

Seppo Makkonen  
Managing Director

# exact

The following symbols are used throughout this manual



Denotes risk of personal injury, loss of life or damage to the tool in case of nonobservance of the instructions in this manual.



Denotes risk of electric shock.

## Contents

### List of contents

#### 1. Guarantee of conformity with EU requirements

#### Foreword

- 3. Technical data
- 3. Electrical safety
- 4. Package contents

#### Safety

- 5. Safety instructions
- 6. Use and limitations

#### Operation

#### Operating instructions

- 7. Before operating the tool
- 8. Connection to the mains power supply
- 8. Precise setting of the cutting point
- 8. Setting the pipe on supports
- 9. Attaching the pipe saw to the pipe
- 9. Piercing the pipe wall
- 10. Sawing around a pipe
- 10. Overload protection
- 10. Straightness of cut and adjusting wheel

- 11. Installing and changing the saw blade
- 11. Service and maintenance instructions

#### 12. Environment /Disposal

#### 12. Guarantee/Guarantee conditions

Exploded view (separate attachment)

Exact Tools Oy  
Särkiniementie 5 D  
00210 HELSINKI  
FINLAND

Tel +358 9 4366750  
Fax +358 9 43667550  
exact@exacttools.com  
www.exacttools.com  
Made in EU

**exact**  **tools**

## Operating, safety, and servicing instructions

Please read this operating, safety, and servicing instructions carefully before using the pipe saw. Also store this instruction book somewhere accessible to everyone using the pipe saw. In addition to these instructions, always follow the official work, health and safety regulations. The Exact PipeCut 170/170E is meant for professional use only.

## Technical data

Model	Pipecut 170	Pipecut 170E
Voltage	230 / 50 Hz	230 / 50 Hz
Power	1010 W	1200 W
Speed when unloaded	4000 r/min	1600-3500 r/min
Intermittent operation	S3 25%	S3 25%
Blade diameter	140 mm	140 mm
Blade attachment hole	62 mm	62 mm
Weight	5,7 kg	5,7 kg
Range of use	Ø 15 mm – Ø 170 mm	Ø 15 mm – Ø 170 mm
Max. pipe wall thickness	steel 6 mm, plastics 14 mm	steel 8 mm, plastics 14 mm

The Exact PipeCut 170/170E pipe saw is manufactured in accordance with the EU standard EN 60745-1 and also standard EN 60745-2-5 exclusive of the requirement which relates to the opening of the blade guards. (The Exact PipeCut 170/170E pipe saws use is made easier by being able to open the blade guard without tools).



The sound pressure level when sawing steel, which is measured according to EN 60745: Model170E LpA = 94 dB (A), LwA = 105dB (A), LpCpeak = 98 dB (C). Model170 LpA = 86 dB (A), LwA = 97dB (A), LpCpeak = 98 dB (C). When sawing various types of material the sound level vary and may exceed the 85 dB(A) level. Always use ear protectors to protect yourself!

Vibration level: The weighted acceleration value according to EN 60745 does not exceed  $2.5 \text{ m/s}^2$ .

### Electrical safety

The electric motor is designed to be used at the specified voltage only. It can be loaded intermittently for 2.5 min during a 10 min time span (S3 25 %). Always check that the power supply corresponds to the voltage stated on the rating plate. The Exact 170/170E pipe saw is double insulated as required by standard EN 60745-1

Do not take the pipe saw out in the rain. Never use it in wet or damp conditions.

## Exact PipeCut 170/170E pipecutting system, Package contents:

Please check the package contains the following items:

- Pipecutting System case
- Exact PipeCut 170 or 170E pipe saw
- Hard-metal blade 140 x 62 fitted on the machine
- Cutting supports 4x
- Hex socket key 5 mm and 2 mm fitted to the machine
- Operating instructions

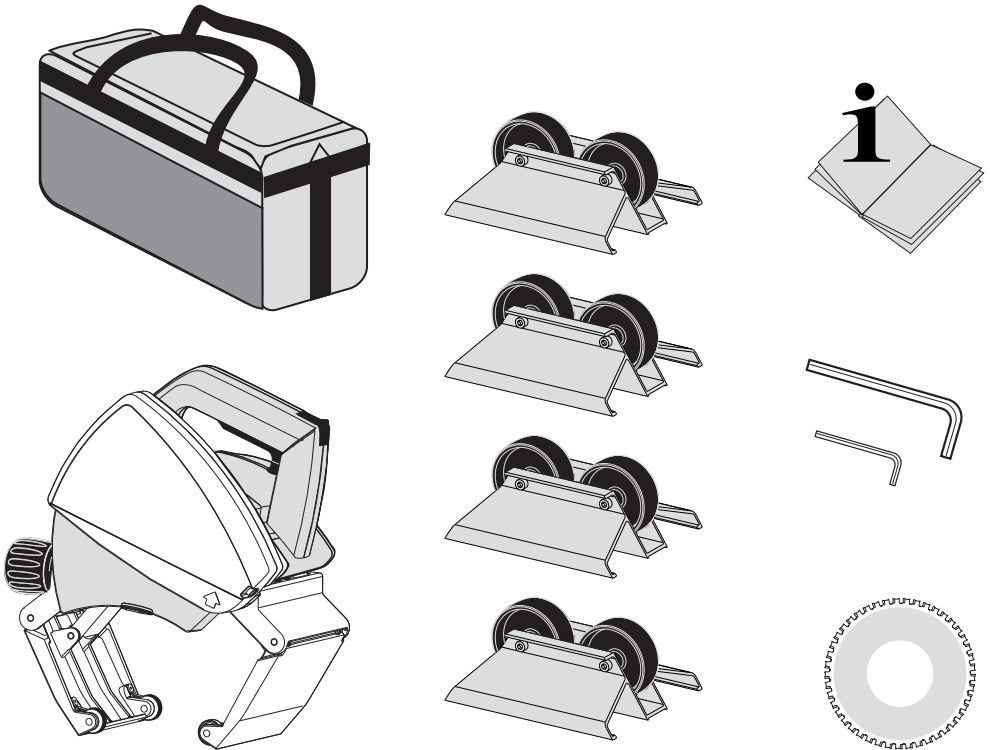

## Safety Instructions

In order to prevent, electrical shocks, injuries, and the risk of fire the following basic safety instructions should be followed.

### Use ear protectors

When working with various materials, the sound level may vary and at times exceed the 85 dB (A) limit. Always use ear protectors to protect yourself.

### Use safety goggles

Always use safety goggles to prevent injury to your eyes from particles thrown up when using the pipe saw.

### Use safety gloves

Always use safety gloves as the edges of cut pipes are sharp and can cause cuts.

### Keep the work area tidy

An untidy work area can be hazardous and may cause an accident.

### Pay attention to where you are working

Do not take the pipe saw out in the rain. Never use it in wet or damp areas. Ensure that the working area is well lit. Never use the pipe saw near flammable liquids or gases. If the pipe saw does get left out in the rain or gets wet in some other way, have it serviced by an approved service agency.

### Protect yourself from electrical shocks

Avoid coming into contact with objects that conduct electricity, such as pipe systems, heating radiators, cookers, washing machines, and refrigerators.

### Keep the pipe saw away from children

Keep children away from the pipe saw and its extension cable. Children under 16 years old must be supervised.

### Store the pipe saw correctly

Always store the pipe saw with the motor unit in the upright position. When you are not using the pipe saw, keep it in a dry place. Ensure that the storage place is locked and high enough to be out of the reach of children.

### Do not overload the pipe saw

Using too great a cutting force or too high a pipe-cutting speed can overload the machine. Always arrange sawing so that when you cut through the pipe

it cannot close in on the sawn gap and clamp onto the blade. The machine works at its best and safest when it is used the way for which it was designed.

### Dress suitably

Do not use clothing that is too loose or jewellery when using the pipe saw as they could get caught on moving parts of the machine. When working outdoors use rubber gloves and non-slip shoes. If you have long hair, use a hairnet.

### Ensure that your work environment is safe

Ensure that no one else is working close to you and that there are no objects that could be damaged by your work.

### Do not damage the power cable

Never carry the pipe saw by its power cable. Do not pull the plug from the socket by pulling on the cable. Protect the power cable from heat, oil, and sharp edges.

### Attach the pipe saw correctly

Always ensure that the gripper unit on the pipe saw is firmly attached on the pipe that is going to be sawn.

### Do not stoop over your work

Always stand maintaining a firm steady stance when using the pipe saw.

### Take proper care of the pipe saw

Keep the pipe saw clean and only use sharp blades. Always follow the servicing instructions and the instructions for changing the blade. Check the condition of the power cable regularly and have it changed by a qualified electrician if necessary. Also regularly check the condition of the extension cable you use and replace it if necessary. Keep the pipe saw's handle dry and clean from oil and grease.

### Take the plug out of the socket

Always disconnect the power to the pipe saw by removing the plug from the socket when the pipe saw is not in use, when you change the blade, or when you service it. Always remove the plug from the socket before removing the blade guard.

### Avoid unintentional starting

Never carry the pipe saw with your finger on the power switch while the saw is connected to its power supply. Check that the power switch is in the off position and the motor is in the upright position before putting the plug into a socket.

## Extension cables outside

When you work outdoors, always use an extension cable that is made and approved for outdoor use.

## Be alert

Concentrate on your work. Use common sense. Do not use the pipe saw when you are tired or drowsy. Never use the pipe saw under the influence of alcohol or drugs.

## Use the right tool

Never use a low-power tool or accessory for work that requires a high-powered tool. Never use the pipe saw for purposes for which it is not intended.

## Remove the key

Check that the blade key has been removed before starting the pipe saw.

## Accessories

Only use additional accessories and equipment recommended by the manufacturer. The use of another manufacturer's accessories may cause an accident.

## Check for damaged parts

Before using the pipe saw, check that: all of its components are in good condition, are correctly installed and that all moving parts operate correctly. Always check the attachments of the blade guard. Also check that everything else that can affect operation is in good condition. Never use the pipe saw if the power switch does not operate properly or if the cable is damaged. A damaged part should be repaired or replaced with a new one at an approved service agency.

## Have your machine repaired at an approved service agency

Your retailer will give you a list of approved service agencies. For safety reasons, only approved service agencies may service or change the machine's electrical components.

## Do not cut pipes containing asbestos

Asbestos is considered to be a carcinogenic substance.

## Check the blade

Use only correct blades in good condition, which are suitable for the material to be cut, for the pipe size and for the speed of the saw

# Intended use and limitations

The Exact PipeCut 170/170E pipe saw is intended for use as a pipe fitter's tool at the installation site. The Exact PipeCut 170/170E pipe saw can only be used to cut round pipes, with a diameter of 15-170 mm and a maximum wall thickness of 6 mm with steel in model 170 or 8 mm in model 170E and 16 mm with plastics. The Exact PipeCut 170/170E pipe saw can be used to cut all normal pipe materials, such as steel, stainless steel, cast iron, copper, aluminum and plastic. Exact PipeCut 170/170E pipe saw is intended for short, intermittent use. The machine may be loaded for 2.5 minutes during a 10-minute period (S3 25 %). Exact PipeCut 170/170E pipe saw is not intended for use in industrial production.

The pipe saw must never be used in the following cases, if:

- There is water or another liquid, explosive gases or poisonous chemicals inside the pipe to be cut.
- The power switch is faulty.
- The power cable is faulty,
- The blade is bent.
- The blade is blunt or in poor condition.
- The plastic components are cracked or have parts missing.
- The gripper unit is not properly tightened around the pipe or if it is warped.
- The blade guard cover or moving blade guard has been damaged or removed from the machine.
- The locking mechanisms do not work properly (UNLOCK-button).
- The pipe saw has become wet.

When using the pipe saw, the following factors must always be taken into consideration:

- Ensure that the pipe to be cut is empty.
- Ensure that the blade is correctly installed.
- Ensure that the diameter and thickness of the blade are suitable for the pipe saw and that the blade is suitable for the rpm-range of the machine.
- Never use sideways force to stop the blade, always allow the blade to stop freely.
- Check the attachments of the blade guards.
- Never use excessive force when using the pipe saw.
- Never use the pipe saw to lift the pipe while it is still attached to the pipe.
- Avoid overloading the electric motor.
- Always follow the safety and operating instructions and current regulations.

Fig. A

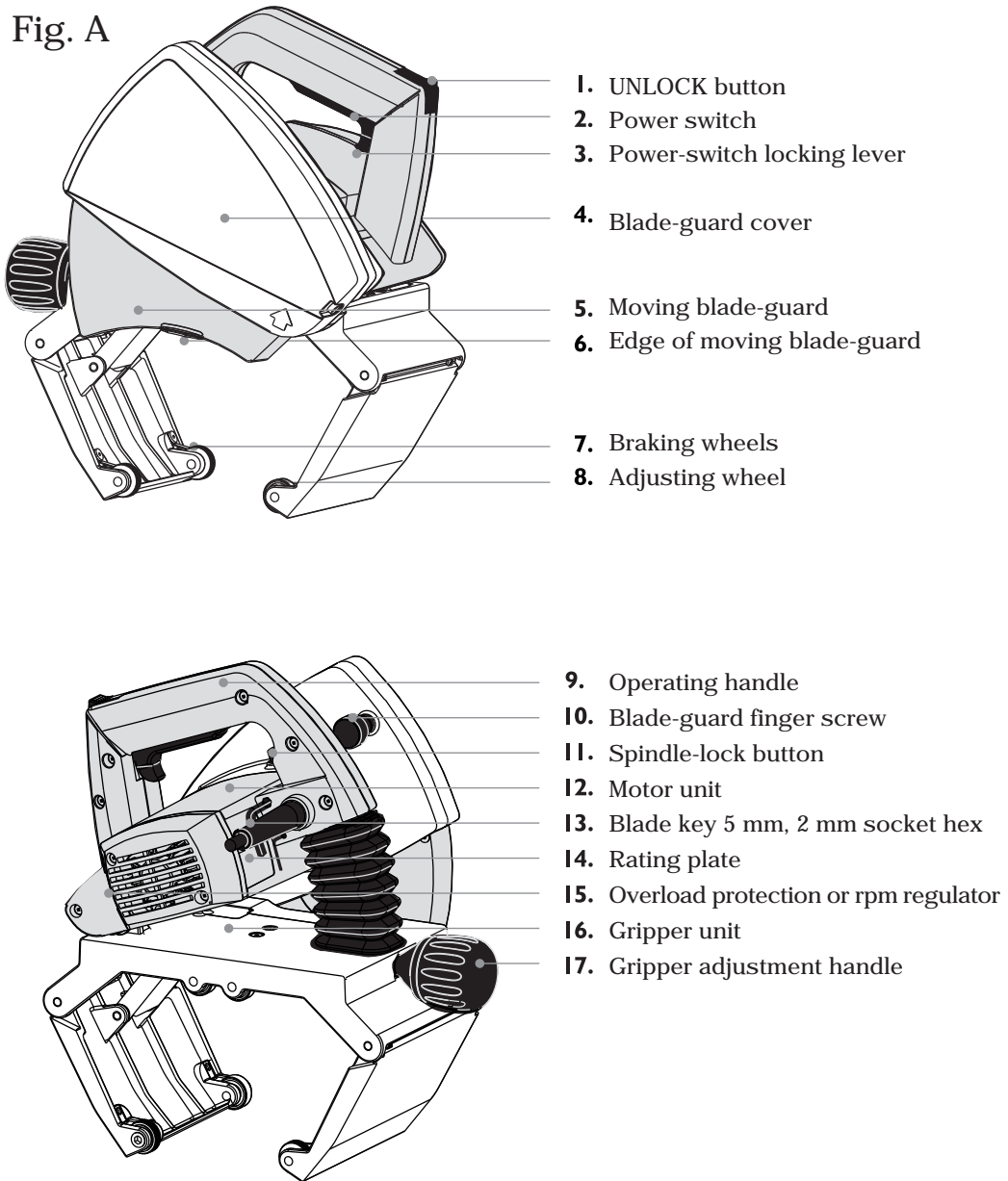

## Exact PipeCut 170/170E pipecutting system operating instructions



Before operating the tool

Ensure that the motor unit is in the upright position. The yellow mark of the UNLOCK button is visible.

Check that the blade is correctly fitted, in good condition and suitable for the material to be cut.

Ensure the pipe saw guide wheels rotate.

Ensure the support wheels rotate.

Check the operation of the lower blade guard.

Ensure the pipe is empty.

If plastic pipes have been cut with the pipe saw (resulting in long, statically charged slivers), open the blade guard cover, and clean carefully the lower blade guard and the entire pipe saw.

### Connection to the mains power supply

Ensure that the mains voltage is the same as indicated on the rating plate (Figure A/14). Connect the pipe saw to the power outlet only after having checked this.

Fig C

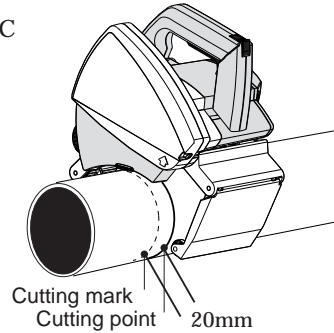

### Precise setting of the cutting point

When you mark the cutting point on the pipe to be cut, deduct 20 mm from the required dimension (Easy-to-remember rule: The cutting mark location requires a measurement of - 20 mm.)(Figure C)

### Setting the pipe on supports

Use the system supports when cutting pipes. This will ensure safe working and optimum result. Work on flat underground. Place the pipe on two supports so that the cutting point is between the supports. Place two more support under both ends of the pipe. Check that all support wheel contact the pipe (adjust if required e.g. with pieces of lumber) (figure B). When cutting short pipes (25cm or less) place the supports so that the cutting point is outside supports (figure D). Support the pipe with your left leg, if required. Proper arrangements will prevent the blade from jamming as the pipe is cut through.

Fig B

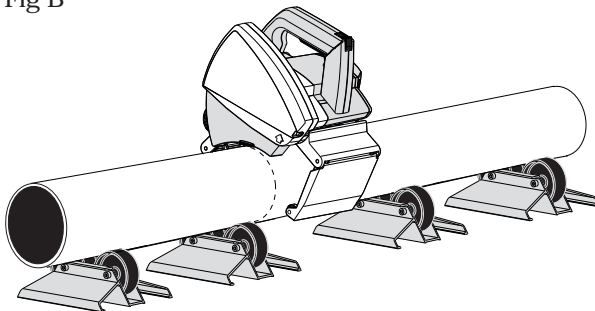
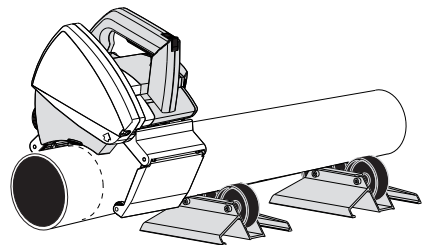

Fig D



## Operation

### Attaching the pipe saw to the pipe

Open the pipe saw's gripper unit enough to suit the diameter of the pipe by rotating the adjustment handle located at the rear of the saw (Fig. E/1). Position the pipe saw on top of the pipe so that the edge of the lower blade guard is at the cutting mark. Fasten the pipe saw to the pipe by turning the gripper adjustment handle until the gripper grips firmly the pipe to be cut (Figure E/2). Hold the pipe in place and ensure that pipe saw moves freely in the direction the pipe is fed. For sake of safety ensure the pipe saw leads are to the left of the pipe saw. The pipe saw is now ready for cutting.

Fig E

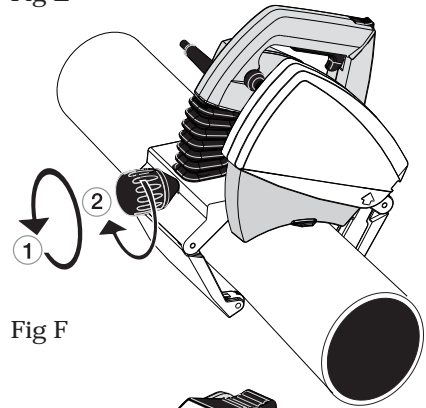

### Piercing the pipe wall

Grip the gripper firmly with your right hand and place your left foot on top of the pipe approximately 50cm from the pipe saw. Turn the saw until it leans slightly forward (Figure H). When starting the motor, first of all release the power-switch locking lever (Fig F/1) and push the power switch all the way down (Fig F/2). Before starting to saw, wait until the blade reaches full speed. Pierce the pipe wall by pressing pipe saw operating handle downwards slowly and evenly until the blade has cut through the pipe wall (at this stage the pipe must not rotate) and the motor unit is locked in the sawing position (Fig H/1).. Look at the UNLOCK button during the piercing operation. When UNLOCK button is locked, i.e. the yellow mark disappears (Fig G), pipe saw is locked in the sawing position, and you can safely start sawing around the pipe.

Fig F

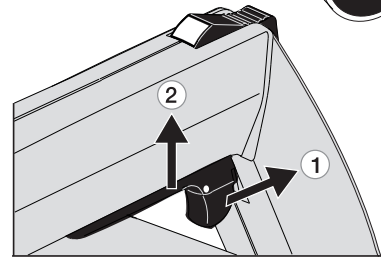
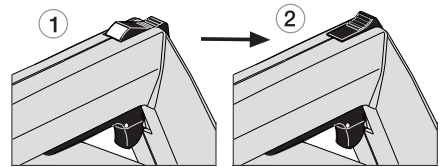

Fig G



### Sawing around the pipe

Start sawing by feeding the pipe saw forward and fix the pipe with your left foot (Fig H/3).. After that release the pipe (remove your left foot from the pipe) and turn the pipe saw backwards, whereby the pipe will also be rotated backwards (Fig J). Start a new feeding movement, and feed continuously forward ca. 1/6 of the pipe's circumference. Repeat until the pipe is cut off (Fig K).

Fig H

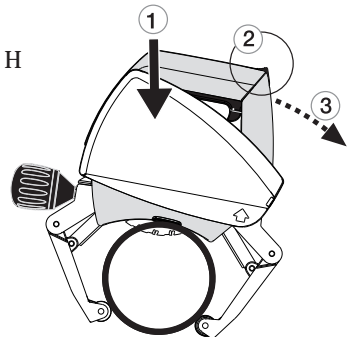

## Operation

Select the feeding speed as per the material and the thickness of the wall. Too high speed can damage the blade, overload the pipe saw and give a poor sawing result.

When the pipe is cut off, push the UNLOCK button forward until the yellow mark is visible and the locking is released (Fig L/1). Now raise the motor unit to starting position (Fig L/2). Release the power switch (Fig L/3). When the blade is stationary, remove the pipe saw from the pipe by loosening the gripped handle (Fig L/4). Ensure that the moving lower blade-guard is lowered into safety position.

Should there be problems during piercing or sawing, abnormal sounds or vibrations due to which you have to interrupt sawing before the pipe is cut through, release the blade by pushing the UNLOCK button forward until the UNLOCK button is released, and lift the motor unit up. Once the problem is cleared, start sawing again.

Never start the motor, when the motor unit is locked in sawing position or teeth of the blade contact the pipe to be sawn.

### Overload protection and spin-speed regulator

Model 170 is equipped with overload protection. When the blade is dull or the cutting speed is too high, the overload protection cuts power automatically. Restore the power by pushing the overload protection switch.

There is a spin-speed regulator in model 170E. A suitable spin speed is selected, determined by the material to be sawed. There is also an overload protection in the regulator. It automatically cuts the power off in an overload situation. The power is automatically restored as soon as the motor has cooled sufficiently. There is a red indicator light in the regulator, which warns of an impending overload and overload protection function. The indicator light in question turns on for a moment every time the motor is started. This is normal and does not require any actions.

### Straightness of cut and adjusting wheel

The cut is affected by many factors, e.g. the size of the pipe, the material, the wall thickness, the quality of the pipe's surface, the roundness, welded seams, blade condition, feed rate, operator's experience. For this reason the result may vary, and the cut may turn to left or right (misalignment of the cut's starting and ending point) (Fig M). The pipe saw gripper has one adjustable wheel (Fig A/9) which be used for improving the quality of the cut and for reducing the misalignment.

Fig J

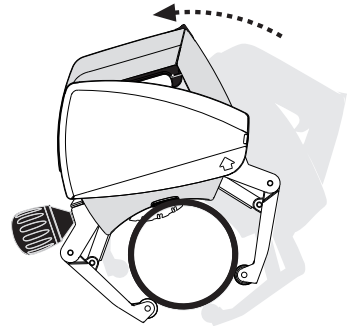

Fig K

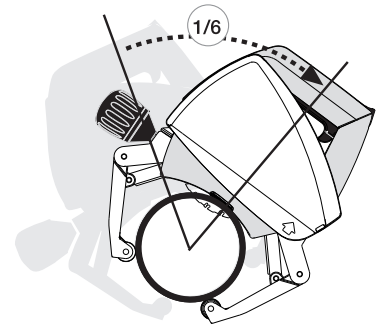

Fig L

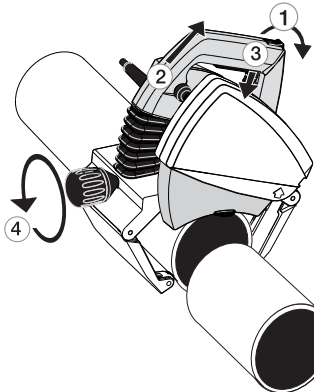

Fig M



Gap to left



Gap to right

## Operation, maintenance

The adjustment applies only to the actual pipe size and material, and the wheel may have to be readjusted as the blade is worn. To adjust the wheel, loosen the locking screw (Fig N/1) and turn the wheel centre clockwise or counter clockwise to the desired position (Fig N/2), and lock the wheel again (Fig N/3). If the blade has wandered too much to the left, adjust wheel centre clockwise (- sign). If the misalignment is to the right, adjust counter clockwise (+ sign). The extent of the adjustment depends on the actual misalignment. Remember to lubricate the adjusting wheel at regular intervals.

Fig N

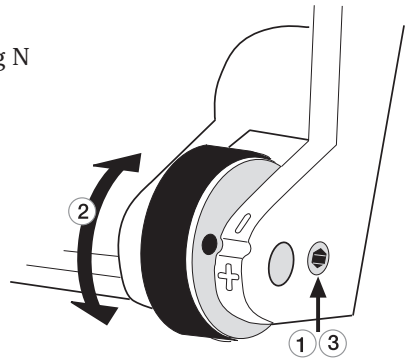
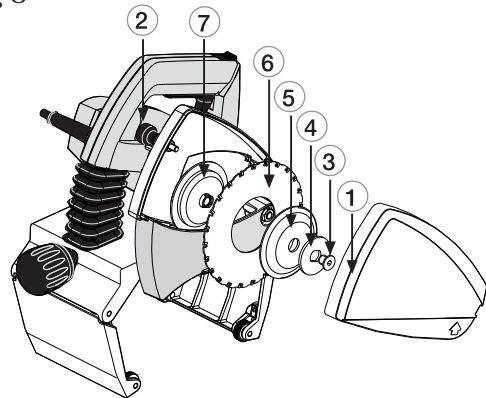

Fig O

Remove the power plug from the socket. Check that the motor unit is locked in the upper position.

Remove the blade guard cover (Fig. O/1) by opening the two finger screws (Fig. O/2). Press the spindle-lock button (Fig. A/11) and simultaneously rotate the blade by hand until the spindle-lock button drops a further distance of about 7 mm. Now the rotation of the blade is prevented. Use the blade key to open the blade attachment bolt. Remove the securing bolt (Fig. O/3), the washer (Fig. O/4), the blade flange disc (Fig. O/5), and the blade (Fig. O/6).



Before installing a new blade, check that both blade flange discs are clean. Place a new or sharpened blade on the back flange disc (Fig. O/7), so that the marked side of the blade is facing outwards and the arrows on the blade are facing in the same direction as the rotation direction markings on the inside of the blade case. Ensure that the new blade goes right to the bottom in the back flange disc. Put the blade flange disc, the washer, and the securing bolt back in place. Press the spindle lock button and tighten the blade guard cover and tighten the finger bolts.

Fig P

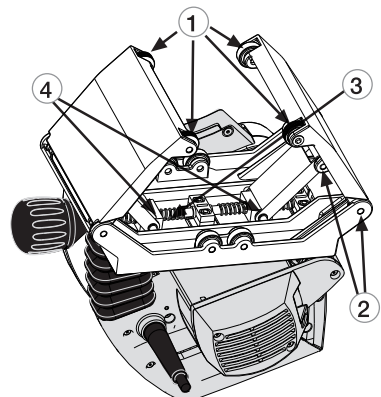

## Maintenance and servicing instructions

Remove the power plug from the socket before servicing or cleaning the pipe saw. All maintenance operations carried out on the pipe saw's electrical components must be carried out at an approved service agency.

### Blade

Check the condition of the blade. Replace a bent, blunt, or otherwise damaged blade with a new one. Using a blunt blade can overload the pipe saw's electric motor. When you notice that the blade is blunt, do not continue sawing with it, as the blade may become so badly damaged that it will not be worth sharpening. A blade in sufficiently good condition can be sharpened a few times by a professional sharpening company. Exact-blades.

### Gripper unit

Clean the gripper unit regularly with compressed air. Lubricate the gripper's wheel axles (Fig. P/1) and its joints (Fig. P/2). Also clean and lubricate the gripper's trapezoidal screw (Fig. P/3) and the two worm screws on it (Fig. P/4).

### Blade guard

When you have sawn plastic pipes and then intend to start sawing metal pipes always clean the inside of the blade guards. Hot particles derived from sawing metal will burn plastic particles, which may release toxic smoke. Make it a rule to clean the blade guard regularly, and pay special attention to keep the moving blade guard movement from becoming hampered. Lubricate the axis of the moving blade guard regularly.

### Motor

Keep the motors cooling vents clean.

### Plastic parts

Clean the plastic parts with a soft rag. Only use mild detergents. Do not use solvents or other strong detergents as they may damage the plastic parts and paint surfaces.



### Power cable

Check the condition of the power cable regularly. A faulty power cable should always be replaced at an approved service agency.

Correct use and regular servicing and cleaning will ensure the continued operation of the pipe saw.

## Environment



Separate collection. This product must not be disposed of with normal household waste. When your Exact PipeCut 170/170E machine is worn out, do not dispose of it with normal household waste. This product must be recycled separately. Separate recycling of used products and packaging facilitate recycling and recovery of materials. Reusing of recycled materials helps prevent pollution of environment. According to local regulations it is possible to deliver household appliances to municipal rubbish depositories or to the dealer when buying a new product.

## Guarantee

If the Exact PipeCut 170/170E pipe saw becomes unusable due to material or manufacturing faults within 24 months of the date of purchase, we will replace the damaged parts with new ones or supply an entirely new or factory-reconditioned pipe saw to replace the damaged one.

The guarantee is only valid if:

The guarantee card or a dated purchase receipt is returned to the manufacturer or retailer.

The pipe saw has not been misused.

No attempt has been made by non-approved persons to repair the saw.

The pipe saw has been used in accordance with these operating, safety, and servicing instructions. The guarantee does not apply to blades or the overload protection.

Due to continuous product development, the information in this instruction book may change. We do not give separate notification of changes.