



WELDING EQUIPMENT

www.r-techwelding.co.uk

email: sales@r-techwelding.co.uk

Tel: 01452 733933 Fax 01452 733939



MTS255S

MIG-TIG-MMA WELDING MACHINE

OPERATION INSTRUCTIONS



Version 2014-1

Thank you for selecting the R-Tech MTS255S Inverter Mig (Synergic) - MMA - TIG Welder.

The MTS255S has many benefits over traditional transformer welders including infinite power control, adjustable arc force and features a heavy duty wire feed mechanism to provide very smooth wire feed and weld characteristics

Ideal for automotive work with its minimum current of 25-30 Amps and industrial welding with its maximum output of 250 Amps (MIG/TIG) and 200 amps (MMA)

We want you to take pride in operating our MTS255S as much pride as we have taken in making this product for you. Please read all information in this manual before operation

PLEASE EXAMINE CARTON AND EQUIPMENT FOR DAMAGE IMMEDIATELY

Please record your equipment identification below for future reference. This information can be found on the data plate at rear of machine.

Product: MTS255S

Serial No.. _____

Date of Purchase _____

Where Purchased _____

Whenever you request replacement parts or information on this equipment please always supply the information you have recorded above

This product is covered by 2 years parts and labour warranty, we will cover cost of collection, repair and returning item to you within mainland UK (other areas are RTB warranty). External items, torch, earth lead etc are covered by 3 months warranty. Any faults/damage found caused by customer will be charged prorata.

Please read this operator manual completely before attempting to use this equipment. Pay particular attention to the safety instructions we have provided you for your protection

The level of seriousness to be applied to each section is explained below

WARNING



This statement appears where the information must be followed exactly to avoid serious personal injury.

CAUTION

This statement appears where the information must be following to avoid a minor personal injury or damage to this equipment.

Product Description

Premium features include:-

- Inverter power source – more efficient to operate, provides smoother weld characteristics.
- Heavy duty wire feed unit for long working life and consistent wire feeding.
- MIG (Synergic) - MMA - DC Tig welding modes
- Infinite welding voltage to allow fine tuning of weld characteristics
- Adjustable arc force – controls splatter – ideal for thin materials
- Synergic Mig Operation with settings for steel, stainless steel and aluminium
- Mig Operation with from 25 amps to 250 amps - ideal for very thin and thick materials
- Digital amp & volts meters
- 9 memory job stores - Easily switch between stored settings for job in hand
- Euro type torch fittings for easy torch fitment/replacement
- 35% Duty cycle at maximum amps @ 40°C

Recommended Processes

The R-Tech is recommended for the MIG welding processes within its output capacity of 250 Amps DC

Equipment Limitations

The R-Tech POWER MTS255S is protected from overloads beyond the output ratings and duty cycle as per machine specifications with thermostat protection of the output coils and rectifiers.

Welding Capability Duty Cycle

The R-Tech MTS255S is rated at 250 Amps(MIG) at 35% duty cycle on a ten minute basis. If the duty cycle is exceeded a thermal protector will shut machine off until the machine cools.

The R-Tech MTS255S is rated at 200Amps(MMA) at 35% duty cycle on a ten minute basis. If the duty cycle is exceeded a thermal protector will shut machine off until the machine cools.

The R-Tech MTS255S is rated at 250 Amps(TIG) at 35% duty cycle on a ten minute basis. If the duty cycle is exceeded a thermal protector will shut machine off until the machine cools.

Installation

Technical Specifications

Model No.	R-Tech POWER MTS255S	
Input		240V 1 ~ AC 50/60Hz
Operation		
	Rated Input Current	32AMPS
	Rated Output Current	250 AMPS
	Duty Cycle 35% @ 40°C	250A (MIG/TIG) ,200A(MMA)
	Duty Cycle 100% @ 40°C	160A (MIG/TIG),130A(MMA)
	Output current Range	MIG: 30-250 AMPS MMA: 10-200AMPS TIG: 10-250 AMPS
	No Load Voltage	60~80V
	MIG Voltage Adjustment Range	14V - 29V± 3V
	Suitable Wire Diameter	0.6mm 0.8mm 1.0mm
Insulation		Class F

Read entire section before starting installation

WARNING!



Electric Shock can kill Only qualified personnel should perform this installation. Turn off input power at the fuse box before working on this equipment. Do not touch electrically live parts. Always connect the machine to an earthed mains supply as per national recommended standards.

Select suitable location

Place the welder where clean cooling air can freely circulate in and out of the front & rear louvre vents. Dirt, dust or any foreign material that can be drawn through vents into welder must be kept to a minimum. Failure to observe these precautions can result in excessive operating temperatures which can lead to plant failure.

Grinding

Do not direct grinding particles towards the welder. An abundance of conductive material can cause plant failure.

Stacking

This machine cannot be stacked.

Transport & Unloading

Never underestimate the weight of equipment, never move or leave suspended in the air above people. Use recommended lifting equipment at all times.

WARNING!



Falling Equipment can cause injury. Never lift welder with gas bottle attached. Never lift above personnel.

Tilting

Machine must be placed on a secure level surface or on a recommended undercarriage/trolley. This machine may topple over if this procedure is not followed.

Environmental Rating

The welding power source carries the IP21S rating. It may be used in normal industrial and commercial environments. Avoid using in areas where water / rain is around.

Read and follow the Electric Shock Warnings in the safety section if welding must be performed under electrically hazardous conditions such as welding in wet areas or water on the work piece.

Machine grounding and High Frequency Interference Protection

This welder must be grounded to earth. See national electrical codes for proper grounding methods.

The high frequency generator being similar to a radio transmitter may cause interference to radio, TV and other electronic equipment. These problems may be the result of radiated interference. Proper grounding methods can reduce or eliminate this.

Radiated interference can develop in the following ways

- Direct interference from welder power source
- Direct interference from the welding leads
- Direct interference radiated from feedback into power lines
- Interference from re-radiation by un-grounded metallic objects.

Keeping these contributing factors in mind, installing equipment as per following instructions should minimize problems.

- Keep the welder input power lines as short as possible and enclose as much of them as possible in metal conduit or equivalent shielding. There should be a good electrical contact between this conduit and ground (Earth).
- Keep the work and electrode leads as short as possible. Tape the leads together where practical.
- Be sure the torch and earth leads rubber coverings are free from cuts and cracks that allow welding power leakage
- Keep earth lead connection to work in good condition Clean area on workbench where earth clamp is situated on a regular basis.

Input Connections

Make sure the voltage, phase and frequency of input power is as specified on machine rating plate located at rear of machine.

Have a qualified electrician provide suitable input power as per national electrical codes. Make sure machine is earthed / grounded.

Make sure fuse or circuit breaker is correct rating for machine. Using fuses or circuit breakers smaller than recommended will result in nuisance shut off from welder inrush currents even if welding at low amperages.

On multiple voltage input welders, be sure the machine is connected as per the instructions for the voltage being supplied to welder. Failure to follow these instructions can cause immediate failure within the welder and void machines warranty.

WARNING!



ELECTRIC SHOCK CAN KILL

Turn the input power OFF at the mains switch & fuse box before working on this equipment.

Have a qualified electrician install & service this equipment.

Allow machine to sit for 5 minutes minimum to allow the power capacitors to discharge before working inside this equipment. Do not touch electrically live parts

The POWER MTS255S Inverter Tig Welder requires a 240V 50/60Hz 32amp fused supply. It comes with a 3 metre mains cable attached.

Connect wires according to national coding. (Below states UK coding)

Brown wire - Live, Blue wire - Neutral, Green/Yellow Wire - Earth (Ground)

Connecting to a mains electrical supply

THIS MACHINE IS OF AN INDUSTRIAL SPECIFICATION AND MUST BE FITTED TO A 32AMP 240V MAINS INPUT

Connecting to an Engine Driven Generator

If connecting this machine to an engine driven generator please ensure the following Minimum Generator KVA Output - 10 KVA continuous Generator to be fitted with AVR (automatic voltage regulation)

DO NOT USE ON A GENERATOR WITHOUT AVR, Connecting to a generator without the above minimum requirements may invalidate your warranty.

Controls and Settings

Front Panel

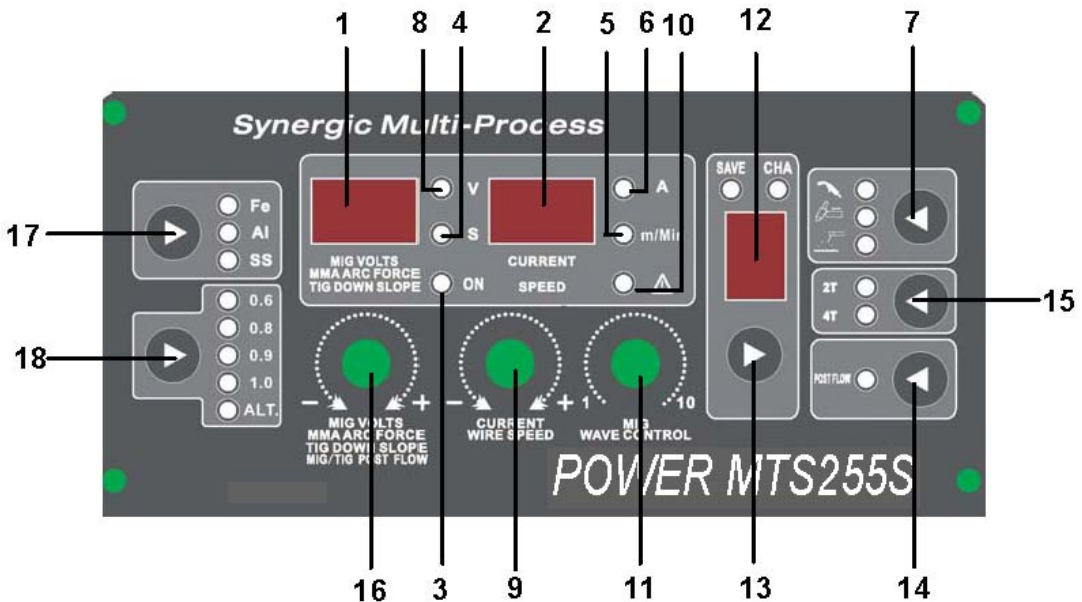

Fig 1

1) Voltage /MMA Arcforce/TIG down slope Display

- The meter on the front panel can indicate the actual welding voltage or preset MIG voltage. The indicating number has the precision of 0.1V .The meter indicates the preset during no welding.
- Display MMA Arcforce
- Display TIG down slope time

2) Current /Wire speed indicating

The current indicating meter on the front panel indicates the actual welding current during the welding, indicates the wire speed during no welding.

3) Power indicating

If the indicating light is on the control circuit connects the power already.

4) TIG down slope time or post flow time

5) Wire speed - When lit LED display will show wire feed speed

6) Current - When lit LED display will show amperage

7) MIG/TIG/STICK Process Selector

Each icon graphically represents each process. The top function represents MIG. The middle function represents TIG. The bottom function represents Stick.

8) Voltage - When lit LED display will show welding voltage

9) Tig welding current / MIG Wire Speed Trim Adjustment Knob

For MIG Synergic operation, the amps are directly tied to the wire speed feed. Using this knob you can fine tune the wire feed speed +/- from synergic setting. This is helpful as sometimes wire sizes can vary slightly and this allows you to trim the feed speed to obtain the optimum weld bead.

For Mig ALT manual mode, this controls the wire feed speed.

For TIG operation this controls the welding amperage

10) Duty Cycle / Over current Warning

When the duty cycle has been exceeded or an over current condition will occur, the L.E.D. will light. Allow the unit to cool while running until the light goes off or for 10 minutes before resetting the welder. If the condition persists check for loose wires or voltage supply problems or call R-Tech support.

11) MIG Wave Form Control

Varies the slope of the current rise time during short circuit MIG operation. This affects the actual point where the current has risen sufficiently to melt the wire.

12) Memory channel LED

13) CH (channel) / SAVE Process Selector

Pressing button will change memory store number and show values stored. To set up a new memory store first select number to be programmed, then enter setup parameters as required and then press save for 3 seconds to program current setting to shown memory number.

14) MIG /TIG post flow selector

Press to select post flow, this will be shown in LED (1) and can be adjusted with knob (16)

15) 2T/4T Torch Switch Selector

The torch trigger function is designed to operate for both MIG and TIG functions. To operate in 2T mode, the trigger on either the MIG or TIG torch should be simply held down. The 4T function operates as a torch "latch" in MIG mode that locks the MIG torch on without needing to hold the trigger.

To operate 4T in MIG mode, simply press the torch trigger and hold it down until the arc starts. To lock it

on, release the trigger and you can then weld without holding the trigger down. To stop, the trigger must be pressed again and then released.

The 4T function in TIG mode acts similarly, but in conjunction with the down slope timer. As the torch trigger is pressed for the second time, the trigger should be held in until the downslope timer completes its cycle. The trigger may then be released to end the arc. Releasing before the down slope is finished will terminate the arc immediately.

16) MIG Volt/TIG Down Slope/ MMA Arc Force Control/MIG TIG post flow

In each mode the function of the control changes. In MIG Synergic mode the control is used to adjust the arc voltage and wire feed speed. Both voltage and wire feed speed will change together.

in MIG ALT (manual MIG mode) it controls the welding voltage (power) as shown in fig1.1

While in TIG mode it functions to adjust down slope of the arc current.

In Stick mode, the control is used to vary the automatic arc force current response from 0-100. When used for stick welding the arc force is also known as “dig”, the current is increased as the volts fall off due to a short arc length. This helps maintain the arc by providing more wattage.

17) Wire type selector

Select your wire type according to the basic categories of Fe (Steel), Ss (Stainless Steel) or Al (Aluminum). This input must be made to properly use the Synergic function to automatically adjust the Volts needed to weld at the selected wire speed.

18) Wire Diameter/ALT selector

Select your wire diameter according of the type wire you are using. Selecting the correct wire diameter is critical to optimum Synergic function of the welder, automatically compensating the voltage while the wire speed is adjusted.

For alternate full manual control of the welder to function in “normal” Mig mode, select ALT. This will allow for full, independent control of MIG wire speed and voltage.

Rear machine connections

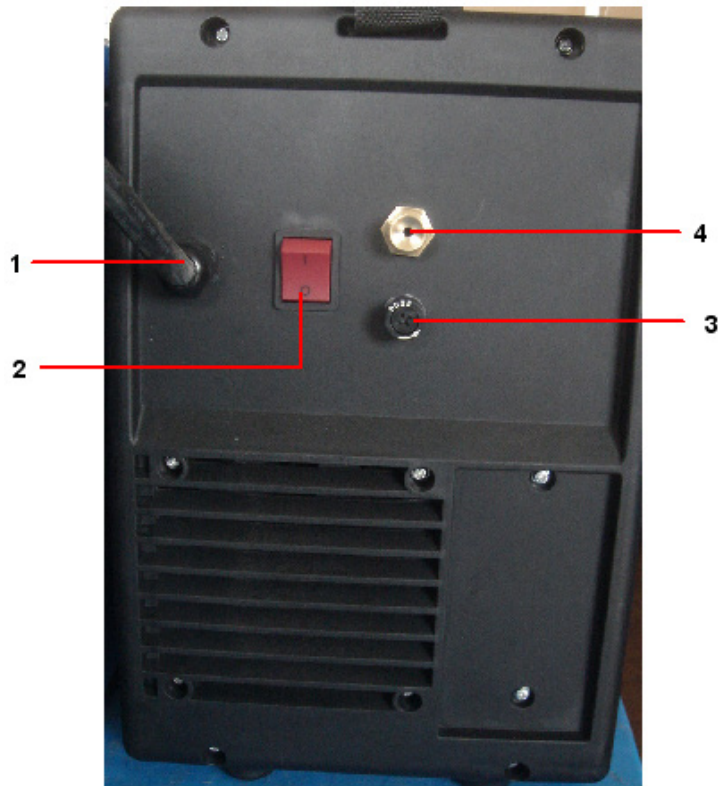

Fig2

- 1 Mains input cable (240V AC input)**
Fit the required plug as per your electrical installation
- 2 On/Off Switch**
- 3 Fuse Holder**
5A fuse for wire speed
- 4 Gas input connector**
Connect input gas hose ensuring connection is tight

Connections for TIG (GTAW) Welding

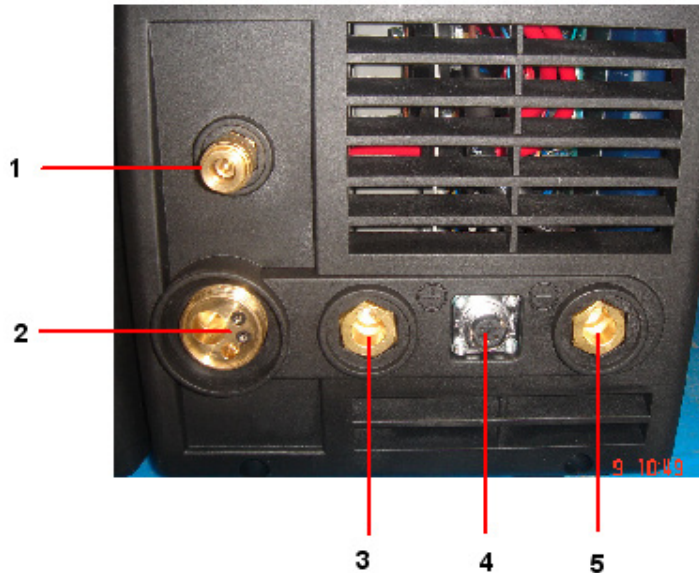
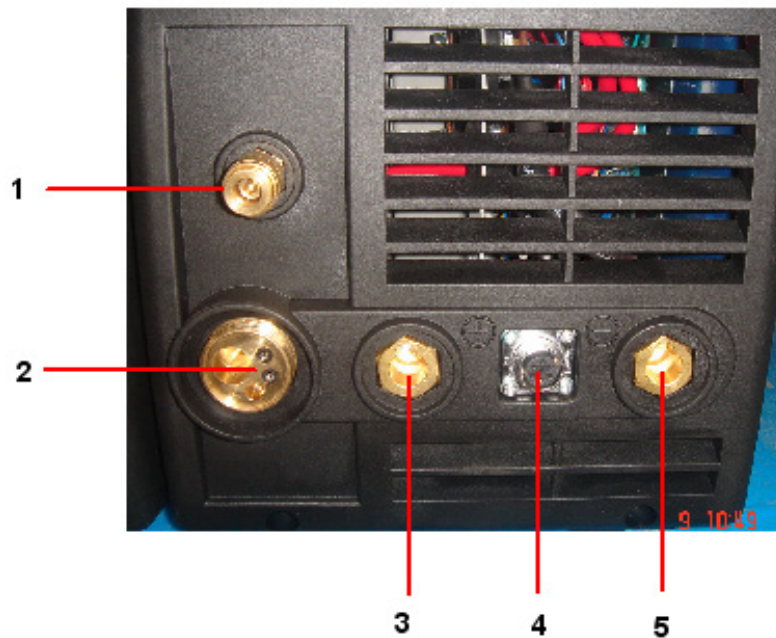

Fig 3

- 1) **Gas outlet**
Connect the TIG torch gas hose quick release connector
- 2) MIG Torch Euro Connector (NOT used in TIG mode)
- 3) **Positive power connector +**
Connect the earth lead to by inserting and twisting until tight and the earth clamp to work/bench
- 4) **Torch control socket 7-Pin**
Connect torch control plug or Remote Foot Pedal plug.
- 5) **Negative power connector -**
Connect TIG Torch Dinse to power connector by inserting and twisting until tight

Connect the gas input hose to gas regulator and use 'Pure Argon' Gas, available from local suppliers. Set gas flow/pressure to 8-12 LPM, Make sure the gas bottle is secured to avoid injury.

Connections for STICK MMA (SMAW) Welding



- 1 Gas outlet (NOT used in MMA mode)
- 2 MIG Torch Euro Connector (NOT used in MMA mode)
- 3 **Positive power outlet** – Connect electrode holder lead
4. Remote connection (NOT used in MMA mode)
5. **Negative power outlet** – Connect earth lead

Connections for STICK MIG /MAG Welding

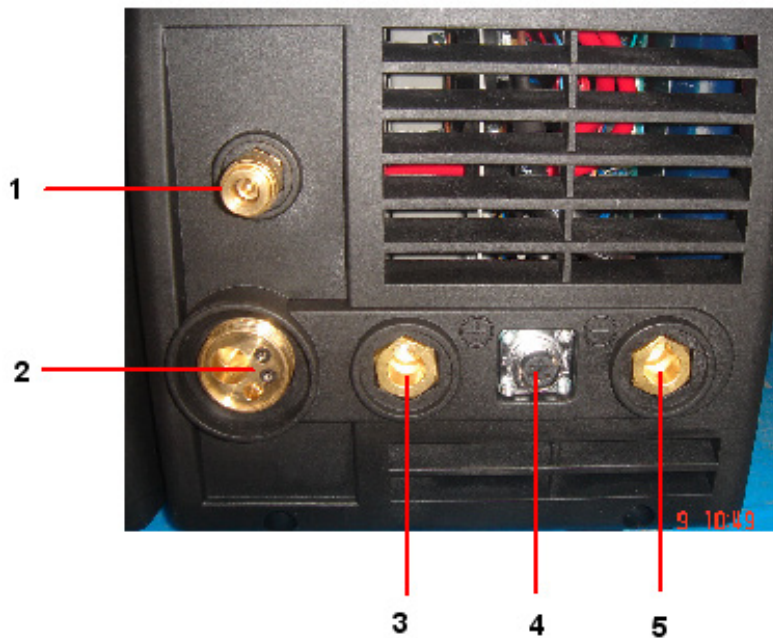

- 1 Gas outlet (NOT used in MIG mode)
- 2 **MIG Torch Euro Connector** - Connect Mig Torch
- 3 Positive - Not normally used unless using gasless wire (reverse polarity)
4. Remote connection (NOT used in MIG mode)
5. **Negative power outlet** – Connect earth lead

Using the wire feed unit

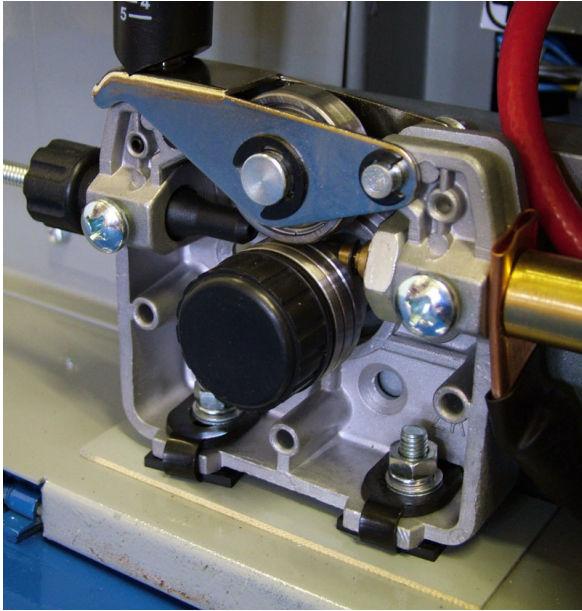

TO INSTALL WIRE:

1. Loosen top tensioner arm, rotating counter-clockwise
2. Flip tensioner down, releasing top drive rolls.
3. Raise top drive rolls.
4. Inspect the drive roll to make sure that the groove size matches the wire diameter. Reversal of the lower roller may be necessary. To reverse the roller, remove the thumb screw securing the drive roll. Pull the drive roll off, and flip the drive roll over. Reassemble and tighten roller. If larger roller is needed, contact R-Tech. Be careful to replace the woodruff key between outer roller and shaft.
5. Thread straightened welding wire over grooves in lower drive roll fully through until it begins to start threading into the gun section. Lower upper drive rolls onto lower drive roll, keeping wire in the groove.
6. Raise tensioner back into place. Tighten slightly so wire will feed. Notice markings on tensioner for future reference.
7. Hold torch straight out as possible. Press gun trigger to feed wire until the wire exits the end of the torch.
8. Adjust tensioner clockwise until drive rolls will not slip when wire comes into contact with surface and the wire will curl up on end. Remember to keep wire away from metal that is attached to the work clamp to prevent the wire from arcing

Connections for using gas/gasless wire

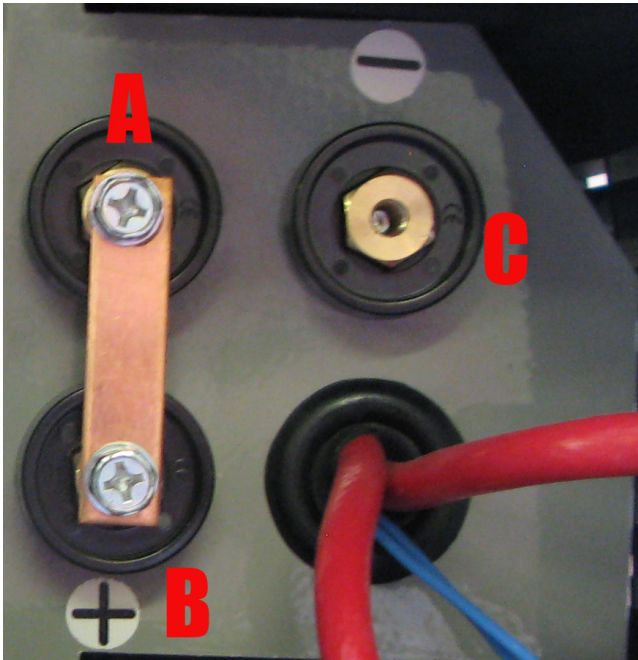

1. Gas type wire

Connect as per diagram above, A is power outlet, B is + to torch

Fit earth lead to - negative connector on front of machine

2. Gasless type wire (reverse polarity required for gasless wire)

Connect brass bar from A to C so torch is negative

Fit earth lead to + positive connector on front of machine

Note:

Ensure machine is disconnected from mains before changing torch polarity.

Operation

SAFETY PRECAUTIONS

WARNING!



ELECTRIC SHOCK CAN KILL

Do not touch electrically live parts or electrode with skin or wet clothing.

Insulate yourself from work and ground

Always wear dry insulating gloves

WARNING!

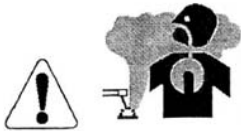

FUMES AND GASES can be dangerous

Keep your head out of fumes & gases produced from welding.

Use ventilation or exhaust to remove fumes & gases from breathing zone and general area.

WARNING!



WELDING SPARKS can cause fire or explosion

Keep flammable material away from work area.

Do not weld on containers that have held combustibles

WARNING!



ARC RAYS can burn

Wear eye, ear and body protection Make sure work area is protected by proper shielding to avoid injury to passers by.

Welding in MIG /MAG Mode

- 1 Connect the MIG Torch to machine, connect earth lead to machine & work piece.
- 2 Set the TIG/MMA/MIG switch to MIG
- 3 Select 2/4 way torch operation
- 4 Set Gas post flow to 1 Seconds, for special applications this can be set to max 10 seconds.
- 5 Select desired welding voltage
- 6 Select desired wire feed speed

Adjust wire feed speed to suit voltage/wire diameter chosen.

Wire reel holder - remove retainer screw cap and fit wire reel and refit securing screw cap. The reel holder features an internal adjustable braking system so that reel of wire stops quickly when the torch trigger released, otherwise the wire reel would continue for a few seconds causing wire to come off the sides.

Wire feed assembly - make sure the rollers are the correct size for the wire diameter selected. To change the rollers release the retaining knurled head screw and fit the rollers onto the shafts making sure the right size groove is in line with the wire and refit retaining screws. Do not over tighten the wire feed pressure rollers as this can cause premature motor and roller failure. TIP: Correct way to adjust tensioner is to slacken off pressure so that the wire does not feed, slowly adjust pressure until wire feeds smoothly, you should be able to stop wire feeding by holding wire and it should slip on rollers. If you have too little pressure the wire will slip when welding causing unwanted burn back into tips, if you have too much pressure wire can snag in rollers when wire hits work and cause wire tangle by rollers.

Welding operation

Once you have set the machine up as per above instructions press the torch trigger to start welding, gas will flow from the torch and main welding power will start and wire feed will start and once wire has touched work piece welding will start, to stop welding release torch trigger.

Adjust the wire feed speed to give the desired weld characteristics

More wire / Less voltage = Dip transfer

Less wire / More voltage = Spray transfer

Welding in TIG mode - No remote foot pedal

- 1 Connect the TIG torch and earth lead to machine & work piece.
- 2 Set the TIG/MMA/MIG switch to TIG
- 3 Select 2 or 4 way torch operation
- 4 Connect Argon gas and set flow to approx 8-12 LPM
- 5 Set Gas post flow to 6 - 10 Seconds, higher amperage requires more post flow.
- 6 Adjust current to desired welding current
- 7 Press the TIG torch switch to start welding

Welding in TIG mode - with Remote foot pedal

- 1 Connect the TIG Torch to machine, connect earth lead to machine & work piece.
- 2 Connect remote foot pedal to machine
- 3 Set the TIG/MMA/MIG switch to TIG
- 4 Select 2 way torch operation
- 5 Connect Argon gas and set flow to approx 8-12 LPM
- 6 Set Gas post flow to 6 - 10 Seconds, higher amperage requires more post flow.
- 7 Press the foot pedal to start welding.

Note: When welding with the remote foot pedal

Upon pressing of foot pedal welding arc will start, if you find it hard to start an arc push the pedal down a bit further to aid starting.

The benefits of welding with a remote foot pedal is that of greater control of the amount of heat going into the work
- Press the pedal fully to start welding; upon weld pool formation you can slightly release the pedal to decrease the amperage to sustain a perfect weld pool and increase it again as required to sustain the weld characteristics.

Welding in STICK MMA (SMAW) Mode - no remote foot pedal

- 1 Fit MMA electrode holder to machine
- 2 Fit earth lead to machine and to work piece
- 3 Select MMA on MMA/TIG/MIG switch
- 4 Place electrode in holder
- 5 Select desired welding current
- 6 Select desired Arc Force
- 7 Strike arc and weld

Welding in STICK MMA (SMAW) Mode - with remote foot pedal

- 1 Fit MMA electrode holder to machine
- 2 Fit earth lead to machine and to work piece
- 3 Select MMA on MMA/TIG/MIG switch
- 4 Place electrode in holder
- 5 Select desired Arc Force
- 6 Connect remote foot pedal to machine
- 7 Select desired welding current
- 8 Strike arc and weld

SYNERGIC AND BASIC MIG OPERATION

Synergic vs. Manual Setup and Operation

How Synergic MIG operates:

The Synergic function of the MIG (255S) component allows the user to only need to use the wire feed speed control to make the unit operate. The welder is programmed to automatically adjust the voltage based on the users input of wire diameter and filler metal type when the wire speed is increased or decreased by turning the wire speed adjustment knob.

While in the Synergic mode the user can make manual adjustment to “fine tune” the voltage if he chooses by turning the voltage up or down after adjusting the wire feed speed. If the wire speed is re adjusted after manual adjustment to voltage is made, the unit defaults to the synergic mode again and voltage is once again adjusted automatically.

The welder may be used in full manual mode with independent control of the wire feed speed by simply selecting ALT on the wire diameter selector. Settings will not be saved when the unit cycles off and back on and will default to factory settings. If stepping away briefly it is best to keep the unit on, or the settings will not

remember the last settings if it is turned off.

How to setup the Synergic and Manual functions:

1. Turn unit on. Wait for it to go through the power up cycle.
2. Select the MIG icon with the Process Selector button.
3. Select the wire diameter of the wire being used. Selecting ALT defaults unit to full manual mode.
4. Select the filler wire type. Fe= Steel, Al= Aluminum, SS= Stainless Steel.
5. Select 2T or 4T function. 2T is simply press and hold the torch trigger to start and activate the torch.
6. 4T requires the trigger to be pressed to start the arc. Once arc is started the trigger should be released to continue weld. The trigger should once again be pressed, held briefly and then released to terminate the arc when ready.
7. If used in the manual mode (ALT), select the appropriate wire feed speed and voltage to match wire type and size. Listen for a steady frying sound while welding to give you a key as to when it is adjusted properly. If used while in Synergic mode, select the desired wire speed and the voltage will adjust automatically. If a minor voltage adjustment is felt like it is needed while in the synergic mode, simply turn the volt-age knob to increase the voltage from the automatically selected setting. If more wire feed speed is desired, the unit will default back to the automatic setting as the wire feed speed is increased or decreased. However, manual control can once again be asserted over the automatic setting by simply turning the voltage knob once again.
8. Use the Wave Form control to select the desired arc qualities and adjust the arc qualities, whether a stiff, pen-etrating arc with a narrow bead profile and slightly more spatter, or a wider more fluid puddle that easily wets in with low amounts of spatter. Overhead welding usually requires a more stiff penetrating arc. Flat welding will accept a wider more fluid puddle.

Maintenance

Routine and periodic maintenance

WARNING!



ELECTRIC SHOCK CAN KILL

Turn the input power OFF at the mains switch & fuse box before working on this equipment.

Have a qualified electrician install & service this equipment.

Allow machine to sit for 5 minutes minimum to allow the power capacitors to discharge before working inside this equipment.

Do not touch electrically live parts

- 1.Periodically remove the side/top panels of machine and clean out machine with a low pressure dry air line paying particular attention to PC Boards, Fan blades.
- 2.Inspect input and output cables & hoses for fraying, cuts & bare spots
- 3.Keep tig torch and cables in good condition
- 4.Clean air vents to ensure proper air flow and cooling
- 5.The fan motor has sealed bearings which requires no maintenance

Troubleshooting

Service & repair should only be performed by R-Tech welding trained personnel. Unauthorized repairs performed on this equipment may result in danger to the technician and machine operator and will invalidate your warranty. For your safety and to avoid electric shock, please observe all safety notes and precautions detailed throughout this manual

The troubleshooting guide is provided to help you locate possible machine malfunctions.

Simply follow the 3 step procedure below

Step 1 Locate problem (symptom)

Look under the column labeled Problem (symptoms). This column describes possible symptoms that the machine may exhibit. Find the listing that best describes the symptom that the machine is exhibiting

Step 2 Possible Cause

The second column labeled possible cause lists the obvious external possibilities that may contribute to the machine symptom

Step 3 Recommended course of action

This column provides a course of action for the possible cause, generally it states to contact R-Tech welding for repair of machine.

Troubles	Cause	Remedy
1.Fan does not work properly	1.the fan line lose 2.Fan breakage	1.Connect the line 2.Change the fan
2.No indicating on the front panel	1.the power line lose 2.Indicating light broken 3.the fuse or IGBT broken	1.Check the power,Connect the line 2.Change it(φ8) 3.Change the fuse 5A/250Vor Contact with the namufacturer .
3.Over heating light on(warning led lights red or yellow color)	1.aeration is not good 2.The temperature is too high 3.over-load use 4.Thermostat broken 5.Control plate broken	1.get rid of the bar 0.5m around 2.Reduce the temperature 3.Reduce the use loading 4.Change the thermostat(JUC-OFF) 5.Check and change the control plate
4.Over-current light ON (warning led lights green color)	1.IGBT broken 2.output diode broken 3.Drive plate broken 4.Control plate broken 5.over current welding	Contact the manufacturer
5.Wire feeder not work (welding current not adjustable)	1.the fuse broken 2.Potentiometer line fall down or Potentiometer broken 3.the wire blocked 4.the drive circuit broken 5.other reasons	1.Change the fuse 5A/250V (on left panel, open wire feeder case) 2.Connect the lines or Change it 3.Check the gun 4.Change the control panel 5.Contact with the manufacturer
6.Welding Voltage not adjustable	1.Potentiometer line fall down 2.Potentiometer broken 3.The circuit broken	1.Connect the lines 2.Change it 3.Change the control pcb
7.Welding stops, and warning light is on	Self-protection has engaged 1.Display "801" 2.Display "802" 3.Display "804" 4.Display "805"	1.over-voltage, lower-voltage 2. over-temperature, 3.over-current, 4.torch switch always close

Electrical Schematic Diagram

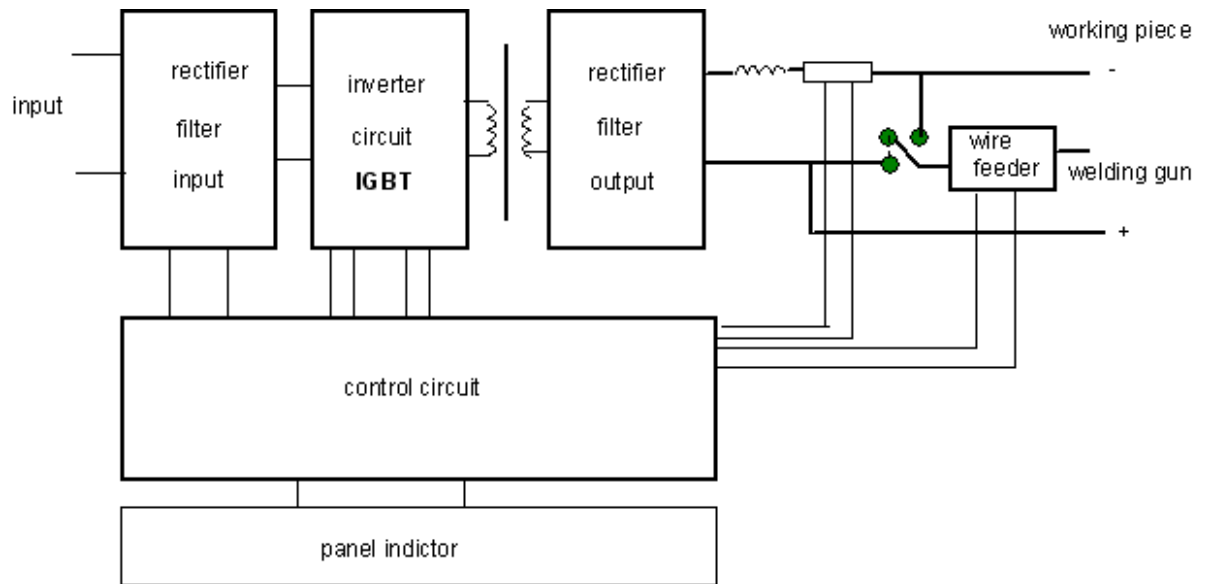

Input AC 220V/230V/240V,rectifier and filter it into 300VDC.

Control the IGBT by PWM+PFM,inverter the 300VDC to 40KHz AC.

High frequency transformer pass the power by insulation and voltage reducing with high efficiency.

Output the second rectifier and the second filter. Output the required welding current and voltage.

Wiring diagram

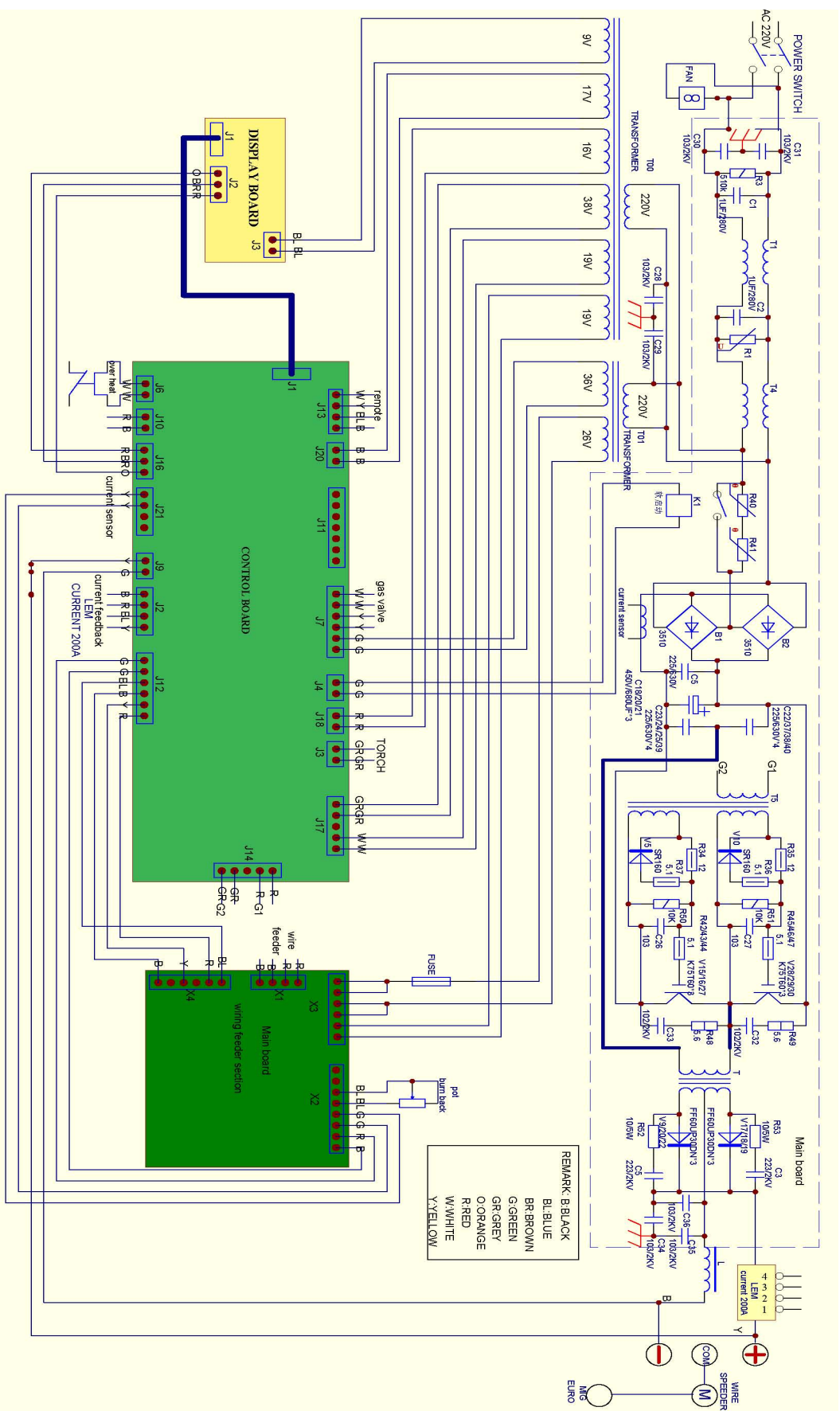

			
WARNING	<ul style="list-style-type: none"> Do not touch electrically live parts or electrode with skin or wet clothing. Insulate yourself from work and ground. 	<ul style="list-style-type: none"> Keep flammable materials away. 	<ul style="list-style-type: none"> Wear eye, ear and body protection.
Spanish AVISO DE PRECAUCION	<ul style="list-style-type: none"> No toque las partes o los electrodos bajo carga con la piel o ropa mojada. Aislese del trabajo y de la tierra. 	<ul style="list-style-type: none"> Mantenga el material combustible fuera del área de trabajo. 	<ul style="list-style-type: none"> Protéjase los ojos, los oídos y el cuerpo.
French ATTENTION	<ul style="list-style-type: none"> Ne laissez ni la peau ni des vêtements mouillés entrer en contact avec des pièces sous tension. Isolez-vous du travail et de la terre. 	<ul style="list-style-type: none"> Gardez à l'écart de tout matériel inflammable. 	<ul style="list-style-type: none"> Protégez vos yeux, vos oreilles et votre corps.
German WARNUNG	<ul style="list-style-type: none"> Berühren Sie keine stromführenden Teile oder Elektroden mit Ihrem Körper oder feuchter Kleidung! Isolieren Sie sich von den Elektroden und dem Erdboden! 	<ul style="list-style-type: none"> Entfernen Sie brennbares Material! 	<ul style="list-style-type: none"> Tragen Sie Augen-, Ohren- und Körperschutz!
Portuguese ATENÇÃO	<ul style="list-style-type: none"> Não toque partes elétricas e electrodos com a pele ou roupa molhada. Isole-se da peça e terra. 	<ul style="list-style-type: none"> Mantenha inflamáveis bem guardados. 	<ul style="list-style-type: none"> Use proteção para a vista, ouvido e corpo.
Japanese 注意事項	<ul style="list-style-type: none"> 通電中の電気部品、又は溶材にヒフやぬれた布で触れないこと。 施工物やアースから身体が絶縁されている様にして下さい。 	<ul style="list-style-type: none"> 燃えやすいものの側での溶接作業は絶対にはなりません。 	<ul style="list-style-type: none"> 目、耳及び身体に保護具をして下さい。
Chinese 警告	<ul style="list-style-type: none"> 皮肤或湿衣物切勿接触带电部件及焊缝。 使你自已与地面和工作件绝缘。 	<ul style="list-style-type: none"> 把一切易燃物品移离工作场所。 	<ul style="list-style-type: none"> 佩戴眼、耳及身体劳动保护用具。
Korean 위험	<ul style="list-style-type: none"> 진도체나 용접봉을 젖은 형갑 또는 피부로 절대 접촉치 마십시오. 모재와 접지를 접촉치 마십시오. 	<ul style="list-style-type: none"> 인화성 물질을 접근 시키지 마시오. 	<ul style="list-style-type: none"> 눈, 귀와 몸에 보호장구를 착용하십시오.
Arabic تحذير	<ul style="list-style-type: none"> لا تلمس الاجزاء التي يسري فيها التيار الكهربائي أو الألكترود بجند الجسم أو بالملابس المبللة بالماء. ضع عازل لا على جسمك خلال العمل. 	<ul style="list-style-type: none"> ضع المواد القابلة للاشتعال في مكان بعيد. 	<ul style="list-style-type: none"> ضع أدوات وملابس واقية على عينيك وأذنيك وجسمك.

READ AND UNDERSTAND THE MANUFACTURER'S INSTRUCTION FOR THIS EQUIPMENT AND THE CONSUMABLES TO BE USED AND FOLLOW YOUR EMPLOYER'S SAFETY PRACTICES.

SE RECOMIENDA LEER Y ENTENDER LAS INSTRUCCIONES DEL FABRICANTE PARA EL USO DE ESTE EQUIPO Y LOS CONSUMIBLES QUE VA A UTILIZAR, SIGA LAS MEDIDAS DE SEGURIDAD DE SU SUPERVISOR.

LISEZ ET COMPRENEZ LES INSTRUCTIONS DU FABRICANT EN CE QUI REGARDE CET EQUIPMENT ET LES PRODUITS A ETRE EMPLOYES ET SUIVEZ LES PROCEDURES DE SECURITE DE VOTRE EMPLOYEUR.

LESEN SIE UND BEFOLGEN SIE DIE BETRIEBSANLEITUNG DER ANLAGE UND DEN ELEKTRODENEINSATZ DES HERSTELLERS. DIE UNFALLVERHÜTUNGSVORSCHRIFTEN DES ARBEITGEBERS SIND EBENFALLS ZU BEACHTEN.

			
<ul style="list-style-type: none"> ● Keep your head out of fumes. ● Use ventilation or exhaust to remove fumes from breathing zone. 	<ul style="list-style-type: none"> ● Turn power off before servicing. 	<ul style="list-style-type: none"> ● Do not operate with panel open or guards off. 	WARNING
<ul style="list-style-type: none"> ● Los humos fuera de la zona de respiración. ● Mantenga la cabeza fuera de los humos. Utilice ventilación o aspiración para gases. 	<ul style="list-style-type: none"> ● Desconectar el cable de alimentación de poder de la máquina antes de iniciar cualquier servicio. 	<ul style="list-style-type: none"> ● No operar con panel abierto o guardas quitadas. 	Spanish AVISO DE PRECAUCION
<ul style="list-style-type: none"> ● Gardez la tête à l'écart des fumées. ● Utilisez un ventilateur ou un aspirateur pour ôter les fumées des zones de travail. 	<ul style="list-style-type: none"> ● Débranchez le courant avant l'entretien. 	<ul style="list-style-type: none"> ● N'opérez pas avec les panneaux ouverts ou avec les dispositifs de protection enlevés. 	French ATTENTION
<ul style="list-style-type: none"> ● Vermeiden Sie das Einatmen von Schweißrauch! ● Sorgen Sie für gute Be- und Entlüftung des Arbeitsplatzes! 	<ul style="list-style-type: none"> ● Strom vor Wartungsarbeiten abschalten! (Netzstrom völlig öffnen; Maschine anhalten!) 	<ul style="list-style-type: none"> ● Anlage nie ohne Schutzgehäuse oder Innenschutzverkleidung in Betrieb setzen! 	German WARNUNG
<ul style="list-style-type: none"> ● Mantenha seu rosto da fumaça. ● Use ventilação e exaustão para remover fumo da zona respiratória. 	<ul style="list-style-type: none"> ● Não opere com as tampas removidas. ● Desligue a corrente antes de fazer serviço. ● Não toque as partes elétricas nuas. 	<ul style="list-style-type: none"> ● Mantenha-se afastado das partes moventes. ● Não opere com os painéis abertos ou guardas removidas. 	Portuguese ATENÇÃO
<ul style="list-style-type: none"> ● ヒュームから頭を離すようにして下さい。 ● 換気や排煙に十分留意して下さい。 	<ul style="list-style-type: none"> ● メンテナンス・サービスに取りかかる際には、まず電源スイッチを必ず切って下さい。 	<ul style="list-style-type: none"> ● パネルやカバーを取り外したままで機械操作をしないで下さい。 	Japanese 注意事項
<ul style="list-style-type: none"> ● 頭部遠離煙霧。 ● 在呼吸區使用通風或排風器除煙。 	<ul style="list-style-type: none"> ● 維修前切斷電源。 	<ul style="list-style-type: none"> ● 儀表板打開或沒有安全罩時不準作業。 	Chinese 警告
<ul style="list-style-type: none"> ● 얼굴로부터 용접가스를 멀리하십시오. ● 호흡지역으로부터 용접가스를 제거하기 위해 가스제거기나 통풍기를 사용하십시오. 	<ul style="list-style-type: none"> ● 보수전에 전원을 차단하십시오. 	<ul style="list-style-type: none"> ● 판넬이 열린 상태로 작동치 마십시오. 	Korean 위험
<ul style="list-style-type: none"> ● ابعء رأسك بعيداً عن الدخان. ● استعمل التهوية أو جهاز ضغط الدخان للخارج لكي تبعد الدخان عن المنطقة التي تتنفس فيها. 	<ul style="list-style-type: none"> ● اقطع التيار الكهربائي قبل القيام بأية صيانة. 	<ul style="list-style-type: none"> ● لا تشغيل هذا الجهاز إذا كانت الاغطية الحديدية الواقية ليست عليه. 	Arabic تحذير

LEIA E COMPREENDA AS INSTRUÇÕES DO FABRICANTE PARA ESTE EQUIPAMENTO E AS PARTES DE USO, E SIGA AS PRÁTICAS DE SEGURANÇA DO EMPREGADOR.

使う機械や溶材のメーカーの指示書をよく読み、まず理解して下さい。そして貴社の安全規定に従って下さい。

請詳細閱讀並理解製造廠提供的說明以及應該使用的銀焊材料，並請遵守貴方的有閱勞動保護規定。

이 제품에 동봉된 작업지침서를 숙지하시고 귀사의 작업자 안전수칙을 준수하시기 바랍니다.

اقرأ بتمعن وافهم تعليمات المصنع المنتج لهذه المعدات والمواد قبل استعمالها واتبع تعليمات الوقاية لصاحب العمل.